

# ELEVATED GARDEN BOX

Bonus Project Plan Included: Extra-Deep Elevated Garden Box

This project is perfect for growing herbs, small plants and flowers, and especially for creating gardens in limited or non-existent yard space. With ProWood® Professional Grade pressure-treated lumber, you can easily build this elevated garden box and enhance the beauty of your yard, deck or patio. It features a sloped bottom for proper drainage and, because it's raised, it's easier on your back and knees. See *fig 1*.

## Materials:

- One 4"x4"x10' ProWood® post
- Two 2"x10"x8' ProWood® lumber
- Four 2"x2"x3' ProWood® square-end balusters
- Two 1"x6"x8' ProWood® deck boards
- One box of 3" #8 exterior wood screws
- One box of 2-1/2" #8 exterior wood screws
- One-third cubic yard quality topsoil or potting soil mix

## Optional:

- Wood glue
- 2'x4' waterproof sheeting (for bed liner)

## Basic Tools:

- Circular and/or table saw
- Mitre saw
- Power drill and 7/64" drill bit
- 1/8" countersink bit
- Screwdriver (or power drill with screwdriving bit)
- Tape measure
- Straightedge
- Carpenter's square

## Optional:

- Utility knife

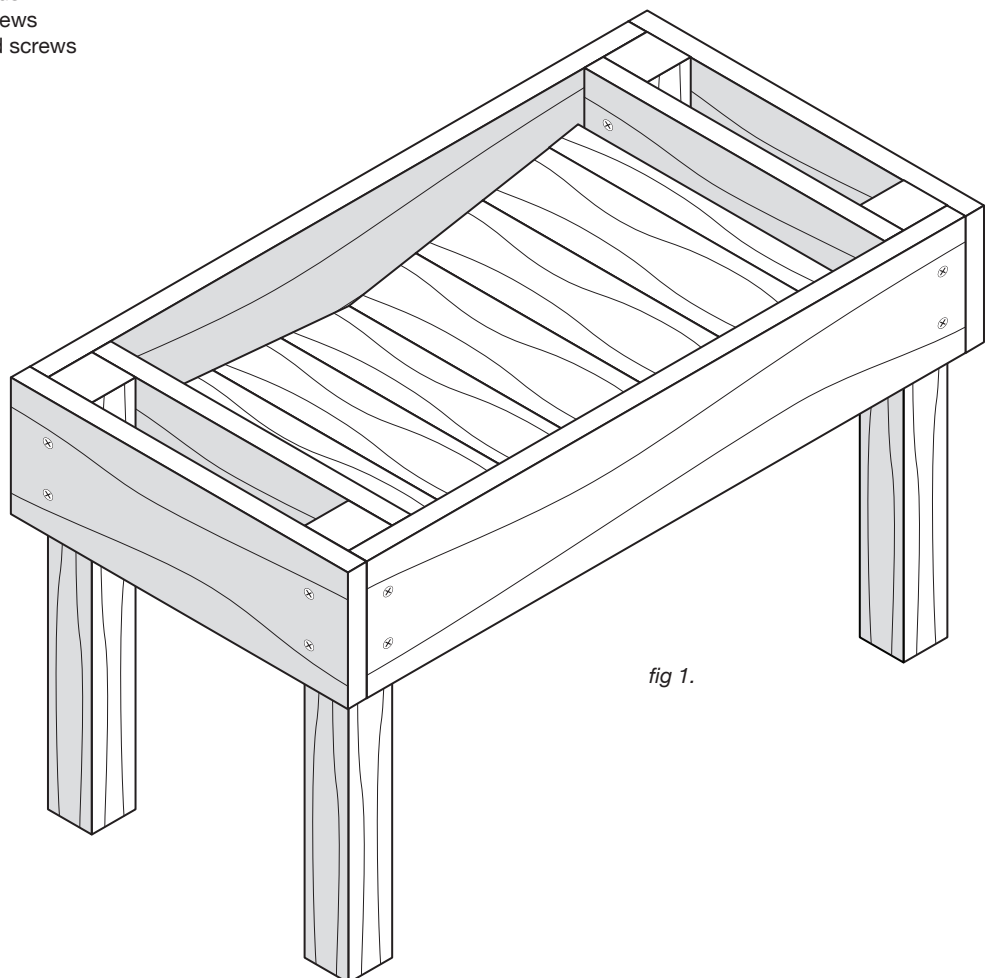

*fig 1.*

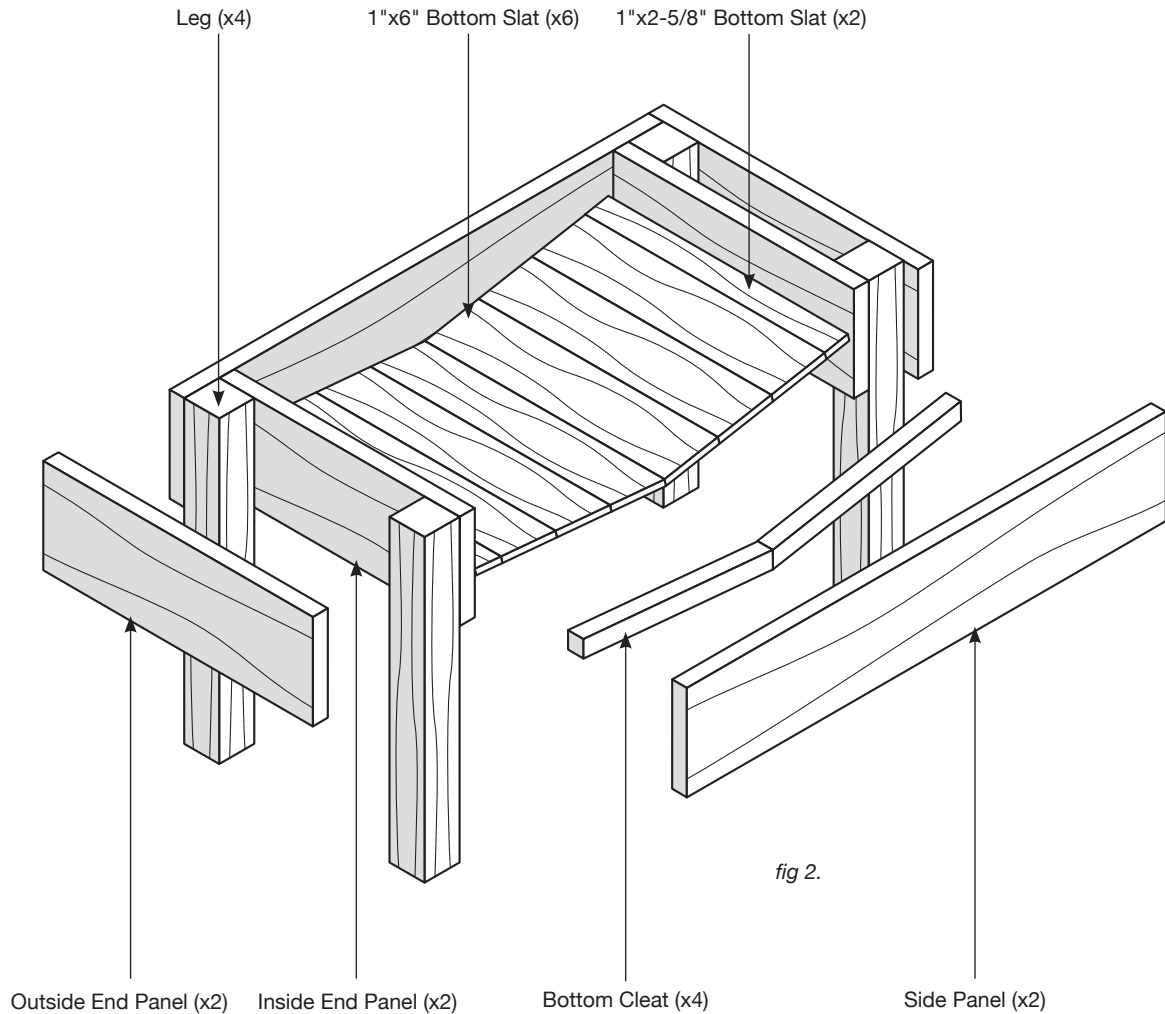

fig 2.

### Cut Wood to Size

*Caution: Always wear gloves, a dust mask and eye protection when sawing, sanding or machining wood. Always use a circular or table saw on a clean, flat and level surface.*

#### Lumber

See fig 2. for the cut wood project components.

Cut the 4"x4"x10' post to to create four 4"x4"x30" legs.

*Tip: Make sure all post ends are cut square.*

Cut the two 2"x10"x8' lumber to the following sizes:

- Side Panels (2): 2"x10"x48"
- Inside End Panels (2): 2"x10"x21"
- Outside End Panels (2): 2"x10"x24"

Rough cut the four 2"x2"x3' square-end balusters to 2"x2"x19-5/8" each. Each cleat will need two mitre cuts later in the process.

Cut the two 1"x6"x8' deck boards to the following sizes:

- Bottom Slats (6): 1"x6"x21"
- Bottom Slats (2): 1"x2-5/8"x21"

### General Assembly Tips

- Establish a screw pattern to enhance the overall look and feel of the final assembled product.
- Pre-drill all screw holes with a 7/64" drill bit to ease screw insertion and prevent wood splitting.
- Countersink all screws so the head of a countersunk screw, when placed in the hole, will sit flush with the surface of the surrounding material.
- Use wood glue to help strengthen all fastened components.

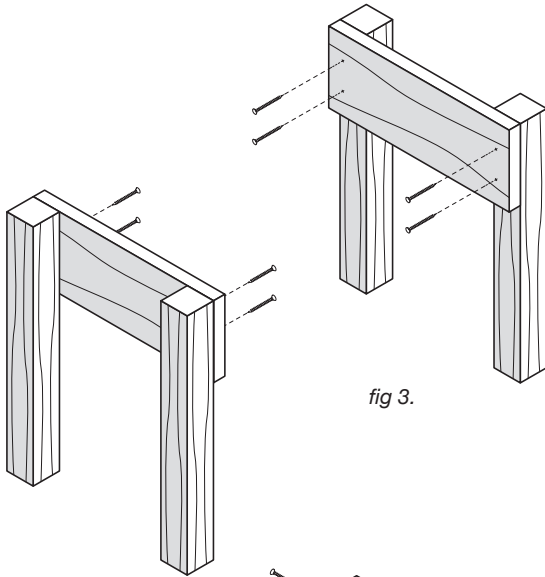

fig 3.

## Build the Base

### Inside End Panels

See fig 3.

- Align each of the two inside end panels with two legs. Make sure the outer edges of the inside end panels are flush with the outer edges of the legs.
- Attach the inside end panels to the legs by pre-drilling and countersinking pilot holes through the panels and into the legs.
- Attach with glue and 3" #8 exterior wood screws.

### Side Panels

See fig 4.

- Align each of the two side panels with the two previously assembled inside end panels. Make sure the outer edges of the side panels are flush with the outer edges of the legs.
- Attach the side panels by pre-drilling and countersinking pilot holes through the panels and into the legs.
- Attach with glue and 3" #8 exterior wood screws.

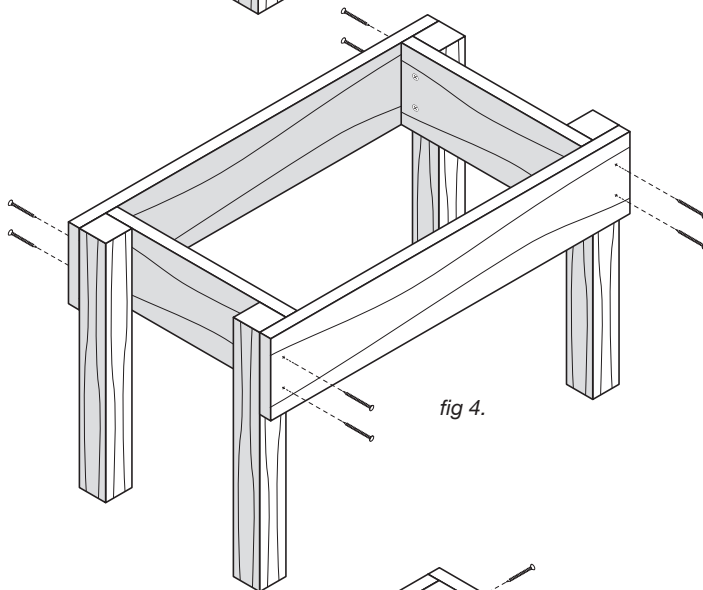

fig 4.

### Outside End Panels

See fig 5.

- Align each of the two outside end panels with the legs. Make sure the outer edges of the outside end panels are flush with the outer edges of the legs.
- Attach the outer end panels by pre-drilling and countersinking pilot holes through the panels and into the legs.
- Attach with glue and 3" #8 exterior wood screws.

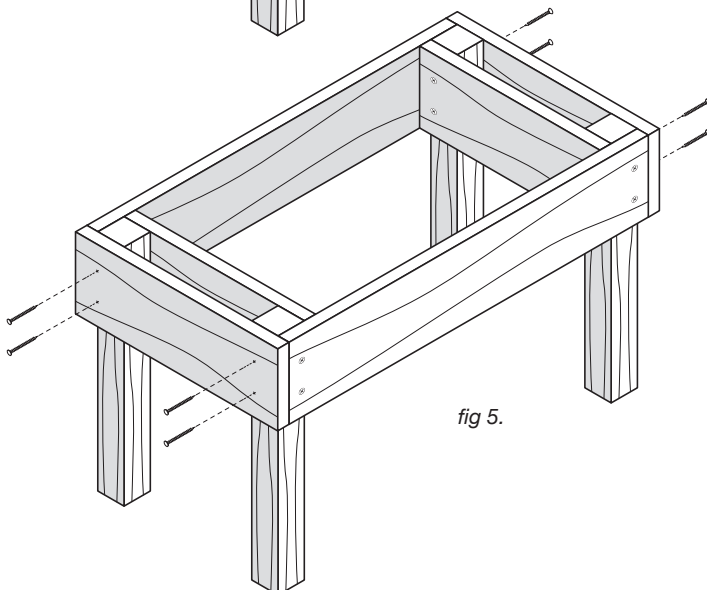

fig 5.

## Build the Bottom

### Bottom Cleats

See fig 6. (cut-away view and insets).

Mitre cut the ends of each cleat.

- Measure and mark a 10° angle (or 1/4") on the outside edges of the four cleats. Make sure the angled marks on each side of the cleat are parallel to each other (see dotted lines on the inset diagrams).
- Use a mitre saw and cut both angles on each cleat.

Attach the cleats.

- To attach the cleats, align the inside angle of two cleats with the inside center of each side panel.
- Make sure the outside angles of the cleats rest against the inside end panels.

See fig 7.

- Pre-drill and countersink pilot holes through the bottom cleats and into the side panels.
- Attach with glue and 2-1/2" #8 exterior wood screws.

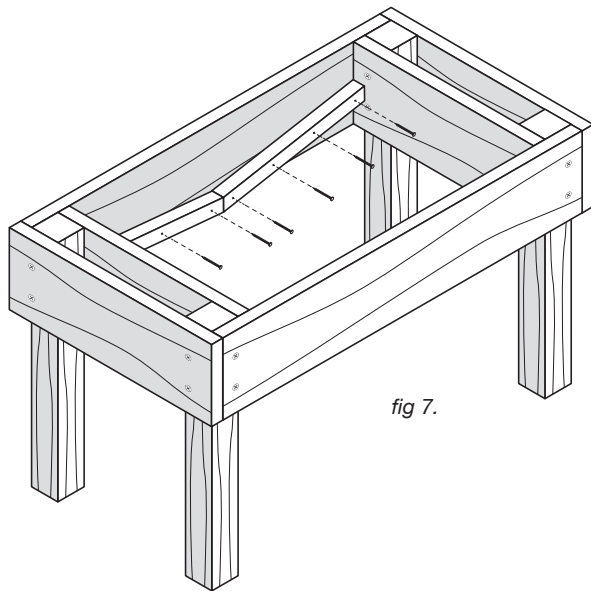
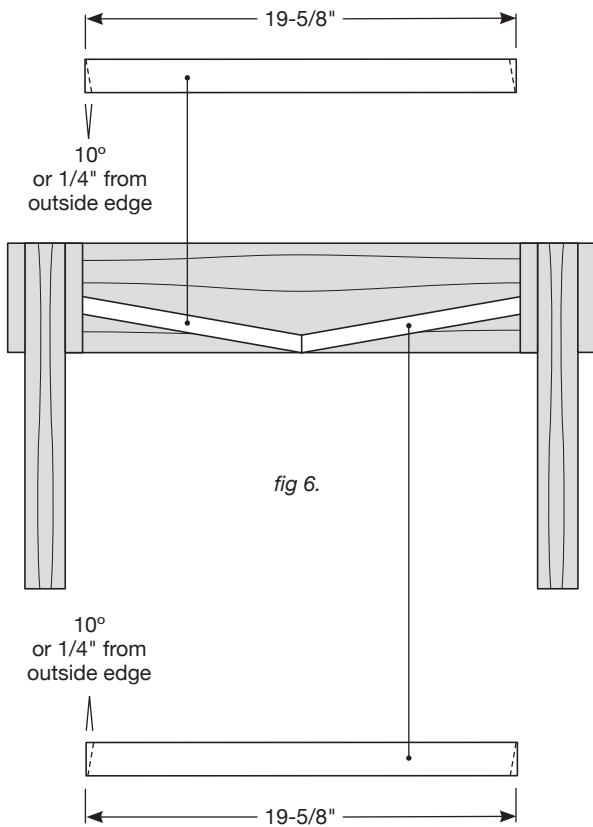

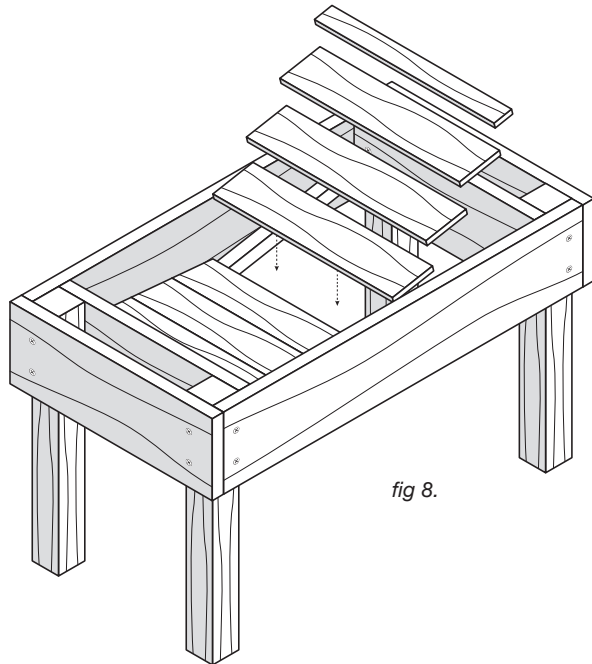

fig 8.

### Insert Bottom Slats

See fig 8.

- Starting with the center of the bottom cleats, place three 1"x6"x21" bottom slats on top of the cleats and next to each other, followed by one 1"x2-5/8"x21" bottom slat on the outside edge.
- Repeat the above process and insert the other set of bottom slats.
- The bottom slats will lie flat on the cleats; no need to drill and screw.

### Optional Bed Liner

You may add a bed liner to help protect the interior of the garden box.

- Measure the inside bottom of the garden box, including its slope, and cut one piece of 2' x 4' waterproof sheeting to size.
- Puncture the sheeting with small holes to allow proper draining.
- Place the waterproof sheeting on top of the bottom slats.

### Add Soil and Seeds or Plants

*Tip: Since this elevated garden box may be too heavy to move once it's filled with soil, it's best to place the box where it's to be located before filling it with soil.*

- Add one-third cubic yard of topsoil or potting soil mix.
- Add seeds or plants.

### Bonus Project Plan:

#### Extra-Deep Elevated Garden Box

See fig 9.

Double the depth of the elevated garden box to accommodate larger plants or those with deeper root depths.

#### Additional Materials

- Two 2"x10"x8' ProWood® lumber
- One-third cubic yard of topsoil or potting soil mix (or a combined total of two-thirds cubic yard)

#### Cut Additional Wood to Size

Cut the additional two 2"x10"x8' lumber to the following sizes:

- Side Panels (2): 2"x10"x48"
- Inside End Panels (2): 2"x10"x21"
- Outside End Panels (2): 2"x10"x24"

#### Build the Extra-Deep Elevated Garden Box

Follow the previous instructions and include the following:

- Attach two additional outside end panels.
- Attach two additional inside end panels.
- Attach two additional side panels.
- Attach the bottom cleats to the two lower side panels.

When the box is built:

- Place the box where it's to be located.
- Add two-thirds cubic yard of topsoil or potting soil mix.

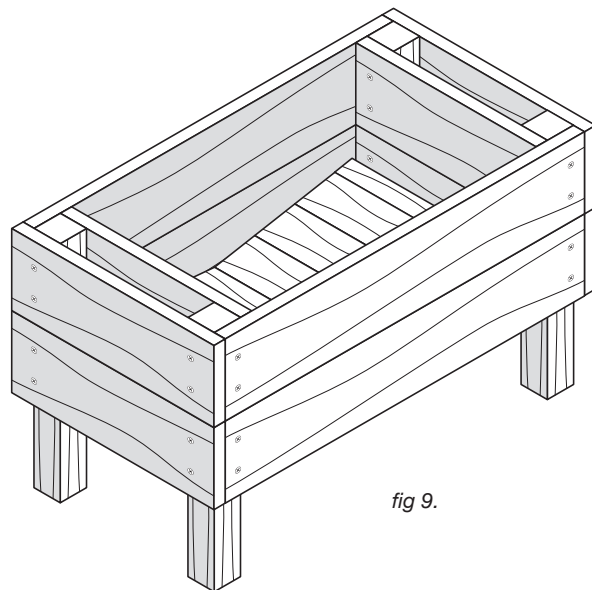

fig 9.

This document is for illustration purposes only. Use of this product must be in accordance with all local zoning and/or building codes. Consumer assumes all risks and liability associated with the use of this product. For details on safe handling, go to [UFPI.com/ptinfo](http://UFPI.com/ptinfo). Warrantor does not provide any warranty, either express or implied, and shall not be liable for any damages, including consequential damages. 7094 06/14