



ICC  
EVALUATION  
SERVICE

In Cooperation with



*Most Widely Accepted and Trusted*

# ICC-ES Evaluation Report

ICC-ES | (800) 423-6587 | (562) 699-0543 | [www.icc-es.org](http://www.icc-es.org)

## ESR-4373

Issued 02/2019

This report is subject to renewal 02/2020.

**DIVISION: 06 00 00—WOOD, PLASTICS AND COMPOSITES**  
**SECTION: 06 05 73.13—FIRE-RETARDANT WOOD TREATMENT**

**REPORT HOLDER:**

**UNIVERSAL FOREST PRODUCTS, INC.**

**EVALUATION SUBJECT:**

**PROWOOD® FR FIRE-RETARDANT-TREATED WOOD**



*“2014 Recipient of Prestigious Western States Seismic Policy Council (WSSPC) Award in Excellence”*



*ICC-ES Evaluation Reports are not to be construed as representing aesthetics or any other attributes not specifically addressed, nor are they to be construed as an endorsement of the subject of the report or a recommendation for its use. There is no warranty by ICC Evaluation Service, LLC, express or implied, as to any finding or other matter in this report, or as to any product covered by the report.*



Copyright © 2019 ICC Evaluation Service, LLC. All rights reserved.

# ICC-ES Evaluation Report

**ESR-4373**

Issued February 2019

This report is subject to renewal February 2020.

[www.icc-es.org](http://www.icc-es.org) | (800) 423-6587 | (562) 699-0543

A Subsidiary of the International Code Council®

**DIVISION: 06 00 00—WOOD, PLASTICS AND COMPOSITES**  
**Section: 06 05 73.13—Fire-Retardant Wood Treatment**

**REPORT HOLDER:**

**UNIVERSAL FOREST PRODUCTS, INC.**

**EVALUATION SUBJECT:**

**PROWOOD® FR FIRE-RETARDANT-TREATED WOOD**

**1.0 EVALUATION SCOPE**

**Compliance with the following codes:**

- 2018, 2015, 2012, 2009 and 2006 *International Building Code®* (IBC)
- 2018, 2015, 2012, 2009 and 2006 *International Residential Code®* (IRC)

**Property evaluated:**

- Flame spread
- Structural
- Corrosion
- Hygroscopicity
- Fire-resistance-rated Wall Assemblies

**2.0 USES**

ProWood® FR fire-retardant-treated wood is used in areas that are not exposed to the weather or wetting, but may be exposed to dampness where the code permits the use of wood or fire-retardant-treated wood.

**3.0 DESCRIPTION**

**3.1 General:**

ProWood® FR fire-retardant-treated wood is lumber and plywood impregnated with ProWood® FR fire-retardant chemicals by a pressure process.

ProWood® FR treatment of lumber of the following species is recognized as being fire retardant:

Southern Pine	Red Pine
Douglas Fir	Ponderosa Pine
Western Hemlock	White Fir
Alpine Fir	Hem Fir
Lodgepole Pine	Balsam Fir
White Spruce	Jack Pine

Spruce-Pine-Fir                      Engelmann Spruce  
Red Spruce                              Black Spruce

ProWood® FR treatment of plywood fabricated with face and back veneers of the following species is recognized as being fire retardant:

Douglas Fir                              Southern Pine

**3.2 Flame Spread:**

ProWood® FR fire-retardant-treated wood has a flame-spread index of 25 or less when subjected to ASTM E84 tests and shows no evidence of significant progressive combustion when the tests are continued for an additional 20-minute period.

**3.3 Structural Strength and Durability:**

The effects of ProWood® FR fire-retardant treatment on the strength of the treated lumber and plywood must be accounted for in the design of the wood members and their connections as required by this section. Load duration factors greater than 1.6 are not permitted to be used in the design.

The strength properties of lumber when treated with ProWood® FR fire-retardant chemicals and used in applications at ambient temperatures up to 150°F (66°C), are subject to the design factors shown in Tables 1 and 2 of this report.

The strength properties of plywood, when treated with ProWood® FR fire-retardant chemicals and used in applications at temperatures up to 170°F (77°C), are subject to the span limitations shown in Table 3 of this report.

**3.4 Corrosion:**

The corrosion rate of aluminum, carbon steel, galvanized steel, stainless steel, copper or red brass in contact with wood is not increased by ProWood® FR fire-retardant treatment when the product is used as recommended by the manufacturer.

**3.5 Hygroscopicity:**

ProWood® FR treated wood qualifies as an Interior Type A (HT) fire-retardant wood in accordance with the American Wood Protection Association (AWPA) Standard U1, Commodity Specification H, Use Category UCFA.

**4.0 DESIGN AND INSTALLATION**

**4.1 General:**

Structural systems that include ProWood® FR fire-retardant-treated lumber or plywood must be designed and installed in accordance with the applicable code using

the appropriate lumber design value adjustment factors and plywood spans from Tables 1, 2 and 3 of this report. Ventilation must be provided in accordance with the applicable codes.

The design value adjustment factors and plywood load and spans in Tables 1, 2 and 3 of this report are applicable under elevated temperatures resulting from cyclic climatic conditions. They are not applicable under continuous elevated temperatures resulting from manufacturing or other processes that require special consideration in design.

The treated lumber and plywood must only be used in areas (including attic spaces) where the lumber is exposed to temperatures of 150°F (66°C) or less and the plywood is exposed to temperatures of 170°F (76.5°C) or less.

Exposure to precipitation during storage or installation must be avoided. If material does become wet, it must be replaced or permitted to dry (maximum 19 percent moisture content for lumber and 15 percent moisture content for plywood) prior to covering or enclosure by wallboard or other construction materials.

#### 4.2 Fasteners:

Fasteners used in ProWood® FR fire-retardant-treated wood must be galvanized steel, stainless steel, silicon bronze or copper, in accordance with Section 2304.10.5 of the 2018 and 2015 IBC, Section 2304.9.5 of the 2012, 2009 and 2006 IBC, Section 317.3 of the 2018, 2015, 2012 and 2009 IRC, and Section R319.3 of the 2006 IRC, and must be subject to the design value adjustments indicated in Table 1 of this report.

#### 4.3 Use as a Component of Fire-resistance-rated Wall Assemblies:

**4.3.1 One-hour Exterior Wall Assembly:** In Type III, Type IV and Type V construction, the exterior wall assemblies must be constructed of ProWood® FR treated wood studs and plywood. The design values for the studs must be adjusted in accordance with Tables 1 and 2. The allowable spans for the plywood sheathing must be in accordance with the spans given in Table 3 for ProWood® FR Wall/Subfloor.

When the fire-resistance rating is required from only the interior side, the wall must be constructed in accordance with Figure 2.

**4.3.2 Two-hour Exterior Wall Assembly:** In Type III, Type IV and Type V construction, the exterior wall assemblies must be constructed of ProWood® FR treated wood studs and plywood. The design values for the studs must be adjusted in accordance with Tables 1 and 2. The allowable spans for the plywood sheathing must be in accordance with the spans given in Table 3 for ProWood® FR Wall/Subfloor.

When the fire-resistance rating is required from only the interior side, the wall must be constructed in accordance with Figure 3.

### 5.0 CONDITIONS OF USE

The ProWood® FR fire-retardant-treated wood described in this report complies with, or is a suitable alternative to what is specified in, those codes listed in Section 1.0 of this report, subject to the following conditions:

**5.1** Strength calculations must be subject to the design factors or span ratings shown in Tables 1, 2 and 3 of this report.

**5.2** The design value adjustment factors and span ratings given in this report must only be used for unincised dimension lumber and plywood of the species noted in this report.

**5.3** ProWood® FR treated wood must not be installed where it will be exposed to precipitation, direct wetting or regular condensation.

**5.4** ProWood® FR treated wood must not be used in contact with the ground.

**5.5** ProWood® FR lumber must not be ripped or milled as this will alter the surface-burning characteristics and invalidate the flame spread classification. Wall, floor and roof framing, consisting of end cuts, holes, joints such as tongue and groove, bevel, scarf, and lap, may be used.

**5.6** Treatment is at the facilities of the listees noted in this report under a quality control program with inspections by ICC-ES and Underwriters Laboratory FR-S, Timber Products Inspection, Inc. (AA-696) or Southern Pine Inspection Bureau (AA-680).

### 6.0 EVIDENCE SUBMITTED

Data in accordance with the ICC-ES Acceptance Criteria for Fire-retardant-treated Wood (AC66), dated June 2015, Editorially Revised April 2018.

### 7.0 IDENTIFICATION

**7.1** Lumber and plywood treated with ProWood® FR fire-retardant chemicals must be identified by the structural grade mark of an approved agency. In addition, all treated lumber and plywood must be stamped with the name of the inspection agency [Underwriters Laboratory FR-S, Timber Products Inspection, Inc. (AA-696) or Southern Pine Inspection Bureau (AA-680)]; Universal Forest Products, name and location; the production plant identification name and location; labeling information in accordance with Section 2303.2.4 of the 2018, 2015, 2012 and 2009 IBC and Section 2303.2.1 of the 2006 IBC or Section R802.1.5.4 of the 2018 and 2015 IRC or Section R802.1.3.4 of the 2012 and 2009 IRC or Section R802.1.3.1 of the 2006 IRC; and the evaluation report number (ESR-4373). Refer to Figure 1.

**7.2** The report holder's contact information is the following:

**UNIVERSAL FOREST PRODUCTS INC.**  
**2801 EAST BELTLINE NE**  
**GRAND RAPIDS, MICHIGAN 49525**  
**(616) 364-6161**  
[www.ufpi.com](http://www.ufpi.com)

**7.3** The Manufacturing Location:

**UFPI HAMILTON, LLC**  
**115 DISTRIBUTION DRIVE**  
**HAMILTON, OHIO 43015**  
**(513) 285-7190**  
[fufkesjr@ufpi.com](mailto:fufkesjr@ufpi.com)

**TABLE 1—STRENGTH DESIGN FACTORS FOR PROWOOD® FR FIRE RETARDANT TREATED LUMBER COMPARED TO UNTREATED LUMBER APPLICABLE AT SERVICE TEMPERATURES UP TO 100°F (38°C)**

STRENGTH DESIGN FACTORS	SOUTHERN PINE	DOUGLAS FIR	SPRUCE-PINE-FIR	OTHER SPECIES
Modulus of Rupture (MOR)	0.82	1.00	0.95	0.82
Modulus of Elasticity (MOE)	0.87	1.00	0.94	0.87
Work to Maximum Load (WML)	0.72	0.93	0.90	0.72
Ultimate Tensile Strength (UTS)	0.99	1.00	0.98	0.98
Maximum Compressive Strength (MCS)	0.96	0.96	1.00	0.96
Ultimate Shear Strength (USS)	0.95	1.00	0.99	0.95
Fasteners/Connectors	0.90	0.90	0.90	0.90

**TABLE 2—STRENGTH DESIGN FACTORS FOR PROWOOD® FR FIRE RETARDANT TREATED LUMBER COMPARED TO UNTREATED LUMBER APPLICABLE AT SERVICE TEMPERATURES UP TO 150°F (66°C) <sup>1,2</sup>**

STRENGTH DESIGN FACTORS	Southern Pine			Douglas Fir			Spruce-Pine-Fir			Other Species		
	Climate Zone			Climate Zone			Climate Zone			Climate Zone		
	1A	1B	2	1A	1B	2	1A	1B	2	1A	1B	2
Modulus of Rupture (MOR)	0.82	0.82	0.82	0.88	0.93	0.98	0.81	0.87	0.93	0.81	0.82	0.82
Modulus of Elasticity (MOE)	0.87	0.87	0.87	1.00	1.00	1.00	0.94	0.94	0.94	0.87	0.87	0.87
Work to Maximum Load (WML)	0.69	0.70	0.71	0.92	0.93	0.93	0.69	0.77	0.87	0.69	0.70	0.71
Ultimate Tensile Strength (UTS)	0.70	0.84	0.96	1.00	1.00	1.00	0.81	0.90	0.97	0.70	0.84	0.96
Maximum Compressive Strength (MCS)	0.66	0.81	0.93	0.84	0.89	0.94	0.83	0.91	0.98	0.66	0.81	0.93
Ultimate Shear Strength (USS)	0.66	0.80	0.93	0.88	0.93	0.98	0.82	0.91	0.97	0.66	0.80	0.93
Fasteners/Connectors	0.66	0.81	0.90	0.84	0.89	0.90	0.83	0.90	0.90	0.66	0.81	0.90

<sup>1</sup> Climate Zone definitions:

Zone 1 – Minimum design roof live load or maximum ground snow load ≤ 20 psf (960 Pa)

Zone 1A – Southwest Arizona, Southeast Nevada (Area Bounded by Las Vegas-Yuma-Phoenix-Tucson)

Zone 1B – All other qualifying areas of the United States

Zone 2 – Maximum ground snow load > 20 psf (960 Pa)

<sup>2</sup> Duration of load adjustments for snow loads, 7-day (construction) loads, and wind loads as given in the *National Design Specification® for Wood Construction®* (NDS) also apply.

**TABLE 3—MAXIMUM LOADS AND SPANS FOR PROWOOD® FR FIRE RETARDANT TREATED PLYWOOD AT SERVICE TEMPERATURES FROM > 100°F (38°C) UP TO 170°F (77°C) <sup>1,2,3,4,5</sup>**

PANEL/SHEATHING THICKNESS	Span Rating for Untreated Roof/Sub-floor Sheathing	ProWood® FR Roof Sheathing Maximum Total Load (psf)				ProWood® FR Wall or Subfloor Span (Inches)
		Span (Inches)	Climate Zone			
			1A	1B	2	
<sup>15</sup> / <sub>32</sub> , <sup>1</sup> / <sub>2</sub>	32/16	24	31	47	68	16
<sup>19</sup> / <sub>32</sub> , <sup>5</sup> / <sub>8</sub>	40/20	24	48	74	107	20
<sup>23</sup> / <sub>32</sub> , <sup>3</sup> / <sub>4</sub>	48/24	32	34	52	76	24
		48	15	23	34	24
<sup>7</sup> / <sub>8</sub>		32	43	66	95	24
		48	19	29	42	24
1		32	58	88	127	24
		48	26	39	57	24
<sup>1</sup> / <sub>8</sub>		32	73	111	161	24
		48	32	49	71	24

<sup>1</sup> For Surface Temperatures < 100°F, use Untreated Span Ratings

<sup>2</sup> Allowable total loads are for unsanded, Structural 1 & 2 Grade plywood, manufactured with Group 1 Species, stress grade S-2 (Fb=1650 psi), one-and-two span conditions.

<sup>3</sup> For allowable live loads, subtract dead loads (assumed to be 8 psf) from total loads listed above.

<sup>4</sup> Climate Zone definitions:

Zone 1 – Minimum design roof live load or maximum ground snow load ≤ 20 psf (960 Pa)

Zone 1A – Southwest Arizona, Southeast Nevada (Area Bounded by Las Vegas-Yuma-Phoenix-Tucson)

Zone 1B – All other qualifying areas of the United States

Zone 2 – Maximum ground snow load > 20 psf (960 Pa)

<sup>5</sup> For other load conditions, contact manufacturer.

## ProWood® FR Sample Labels

 <p style="text-align: center;">Interior Type A High Temperature (HT) Fire Retardant Treated Wood <b>ESR-4373 KDAT</b></p> <p style="text-align: center;">Species Year</p> <p style="text-align: center;">Treater Name • Location</p>	<p><b>UL Classified FR-S PLYWOOD</b></p> <p>FLAME SPREAD/SMOKE DEVELOPED: 30 MINUTE TEST: 25 or less</p> <p>STD-PWFR-19</p>	 <p style="text-align: center;">Interior Type A High Temperature (HT) Fire Retardant Treated Wood <b>ESR-4373 KDAT</b></p> <p style="text-align: center;">Species Year</p> <p style="text-align: center;">Treater Name • Location</p>	<p><b>UL Classified FR-S LUMBER</b></p> <p>FLAME SPREAD/SMOKE DEVELOPED: 30 MINUTE TEST: 25 or less</p> <p>STD-PWFR-19</p>
--	---	---	--

 <p style="text-align: center;">Interior Type A High Temperature (HT) Fire Retardant Treated Wood <b>ESR-4373 KDAT</b></p> <p style="text-align: center;">Species Year</p> <p style="text-align: center;">Treater Name • Location</p>	<p><b>PLYWOOD</b></p> <p>FLAME SPREAD/SMOKE DEVELOPED: ASTM E84 30 MINUTE TEST: 25 or less</p> <p>TP Monitored (AA-696)</p> <p>STD-PWFR-19</p>	 <p style="text-align: center;">Interior Type A High Temperature (HT) Fire Retardant Treated Wood <b>ESR-4373 KDAT</b></p> <p style="text-align: center;">Species Year</p> <p style="text-align: center;">Treater Name • Location</p>	<p><b>LUMBER</b></p> <p>FLAME SPREAD/SMOKE DEVELOPED: ASTM E84 30 MINUTE TEST: 25 or less</p> <p>TP Monitored (AA-696)</p> <p>STD-PWFR-19</p>
--	--	---	---

 <p style="text-align: center;">Interior Type A High Temperature (HT) Fire Retardant Treated Wood <b>ESR-4373 KDAT</b></p> <p style="text-align: center;">Species Year</p> <p style="text-align: center;">Treater Name • Location</p>	<p><b>PLYWOOD</b></p> <p>FLAME SPREAD/SMOKE DEVELOPED: ASTM E84 30 MINUTE TEST: 25 or less</p> <p>SPIB Monitored (AA-680)</p> <p>STD-PWFR-19</p>	 <p style="text-align: center;">Interior Type A High Temperature (HT) Fire Retardant Treated Wood <b>ESR-4373 KDAT</b></p> <p style="text-align: center;">Species Year</p> <p style="text-align: center;">Treater Name • Location</p>	<p><b>LUMBER</b></p> <p>FLAME SPREAD/SMOKE DEVELOPED: ASTM E84 30 MINUTE TEST: 25 or less</p> <p>SPIB Monitored (AA-680)</p> <p>STD-PWFR-19</p>
--	--	---	---

FIGURE 1—LUMBER AND PLYWOOD STAMPS

**Fire Retardant Wood ProWood® FR Lumber and Plywood**  
**ASTM E119 Rating: 1 Hour Load Bearing (2015 NDS – F 0.96 for FRWT)**  
**Rated from One Side (Interior Side Only)**

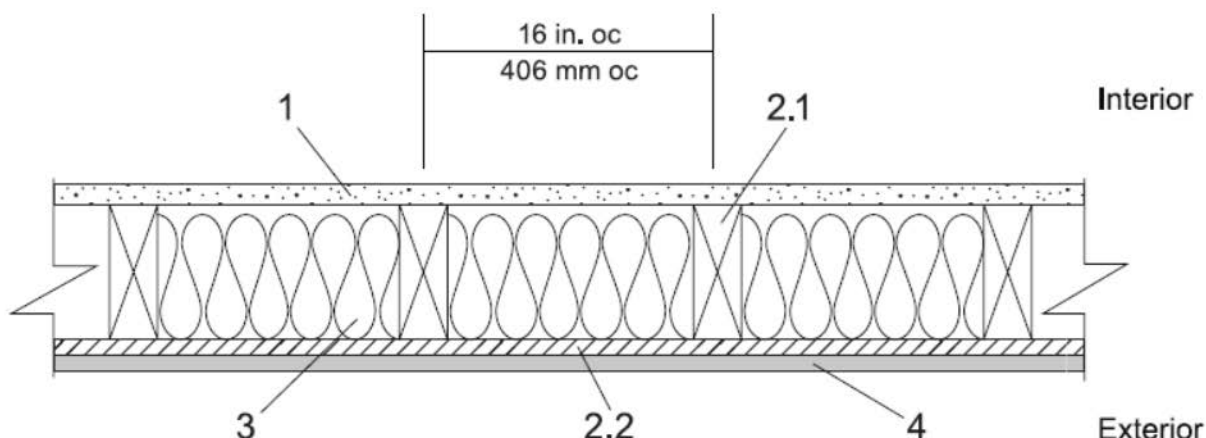

## 1 Hour Load Bearing Wall

**FIGURE 2—ONE-HOUR FIRE RESISTANCE ASSEMBLY**

(For SI: 1 inch = 25.4 mm)

1. **Gypsum Board [Interior]:** One-layer Type C USG Firecode® C Core Type X or equivalent complying with ASTM C1396, min.  $\frac{5}{8}$  in. thick, 4 feet wide applied vertically, fastened to framing. Joints covered with paper tape and joint compound.  
  
**Fasteners (Not Shown):**  
 Min. #6 x 2 in. long Type S or W screws spaced max. 8 in. on center (o.c.) and heads covered with joint compound.
2. **Manufacturer: Universal Forest Products, Inc.**  
**Product: ProWood® FR**
- 2.1 **Model: ProWood® FR Lumber**  
 ProWood® FR Lumber is min. 2x4 in. nominal wood studs, spaced max. 16 in. o.c., double top plates and single bottom plate fastened together with 16d common nails.
- 2.2 **Model (Exterior): ProWood® FR Plywood** ProWood® FR Plywood, min.  $\frac{15}{32}$  in. thick, applied vertically over the specified framing with min.  $2\frac{3}{8}$  in. long, 0.113 in. diameter nails, spaced max. 8 in. o.c. around the perimeter and max. 12 in. o.c. in the field. Horizontal joints must be blocked.
3. **Insulation:** Fiberglass batt insulation min.  $3\frac{1}{2}$  in. thick R-13 friction fit between the studs. If 2x6 in. nominal wood studs are used, fiberglass bait insulation shall be min.  $5\frac{1}{2}$  in. thick.
4. **Exterior Facings (Optional):** Materials installed in accordance with manufacturer's installation instructions:
  - Masonry brick veneer or concrete
  - Portland cement or synthetic stucco systems with self-furring metal lath or adhesive base coat
  - Hardboard, wood structural panel, plywood, or fiber-cement siding
  - Metal siding
  - Vinyl siding - exterior plastic

**Fire Retardant Wood ProWOOD® FR Lumber and Plywood**  
**ASTM E119 Rating: 2 Hour Load Bearing (2015 NDS – F 0.96 for FRWT)**  
**Rated from One Side (Interior Side Only)**

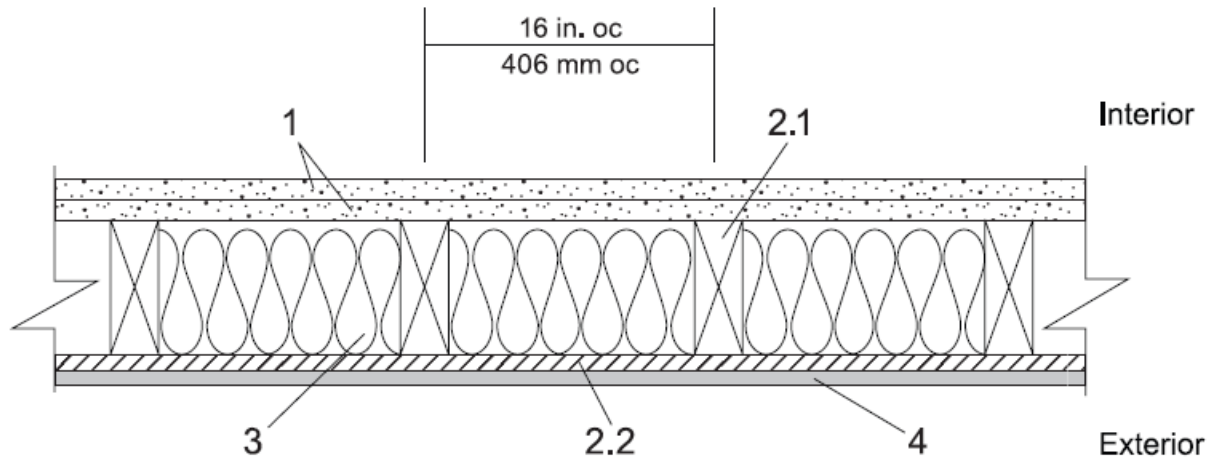

## 2 Hour Load Bearing Wall

**FIGURE 3—TWO-HOUR FIRE RESISTANCE ASSEMBLY**

(For SI: 1 inch = 25.4 mm)

1. **Gypsum Board (Interior):** Two-layers Type C USG Firecode® C Core Type X or equivalent complying with ASTM C1396, min.  $\frac{5}{8}$  in. thick, 4 feet wide applied vertically, fastened to framing. Face layer joints staggered with base layer and covered with paper tape and joint compound.
 

**Fasteners (Not Shown):**

**Face Layer** - Min. #6 x 2 in. long Type S or W screws spaced max. 8 in. on center (o.c.) and heads covered with joint compound.

**Base Layer** - Min. #6 x  $1\frac{5}{8}$  in. long Type S or W screws, spaced max. 6 in. o.c.
2. **Manufacturer:** Universal Forest Products, Inc.  
**Product:** ProWood® FR
  - 2.1 **Model:** ProWood® FR Lumber  
 ProWood® FR Lumber is min. 2x4 in. nominal wood studs, spaced max. 16 in. o.c., double top plates and single bottom plate fastened together with 16d common nails.
  - 2.2 **Model (Exterior):** ProWood® FR Plywood ProWood® FR Plywood, min.  $\frac{15}{32}$  in. thick, applied vertically over the specified framing with min.  $2\frac{3}{8}$  in. long, 0.113 in. diameter nails, spaced max. 8 in. o.c. around the perimeter and max. 12 in. o.c. in the field. Horizontal joints must be blocked.
3. **Insulation:** Fiberglass batt insulation min.  $3\frac{1}{2}$  in. thick R-13 friction fit between the studs. If 2x6 in. nominal wood studs are used, fiberglass bait insulation shall be min.  $5\frac{1}{2}$  in. thick.
4. **Exterior Facings (Optional):** Materials installed in accordance with manufacturer's installation instructions:
  - Masonry brick veneer or concrete
  - Portland cement or synthetic stucco systems with self-furring metal lath or adhesive base coat
  - Hardboard, wood structural panel, plywood, or fiber-cement siding
  - Metal siding
  - Vinyl siding - exterior plastic